

# **SECTION R4:** **STEP INSTALL**

## **PARTS INCLUDED:**

- STEP ASSEMBLIES
- STEP SPACERS
- DRILL TEMPLATE
- 6X BHS-0.250-20-0.750 (1/4"-20 X 0.750" BUTTON HEAD SCREW)
- 6X RN-0.250-20 (1/4"-20 RIVNUT)

## **TOOLS REQUIRED:**

- HEX WRENCH
- #30 DRILL BIT
- 25/64" DRILL BIT
- RIVNUT PULLER
- TAPE

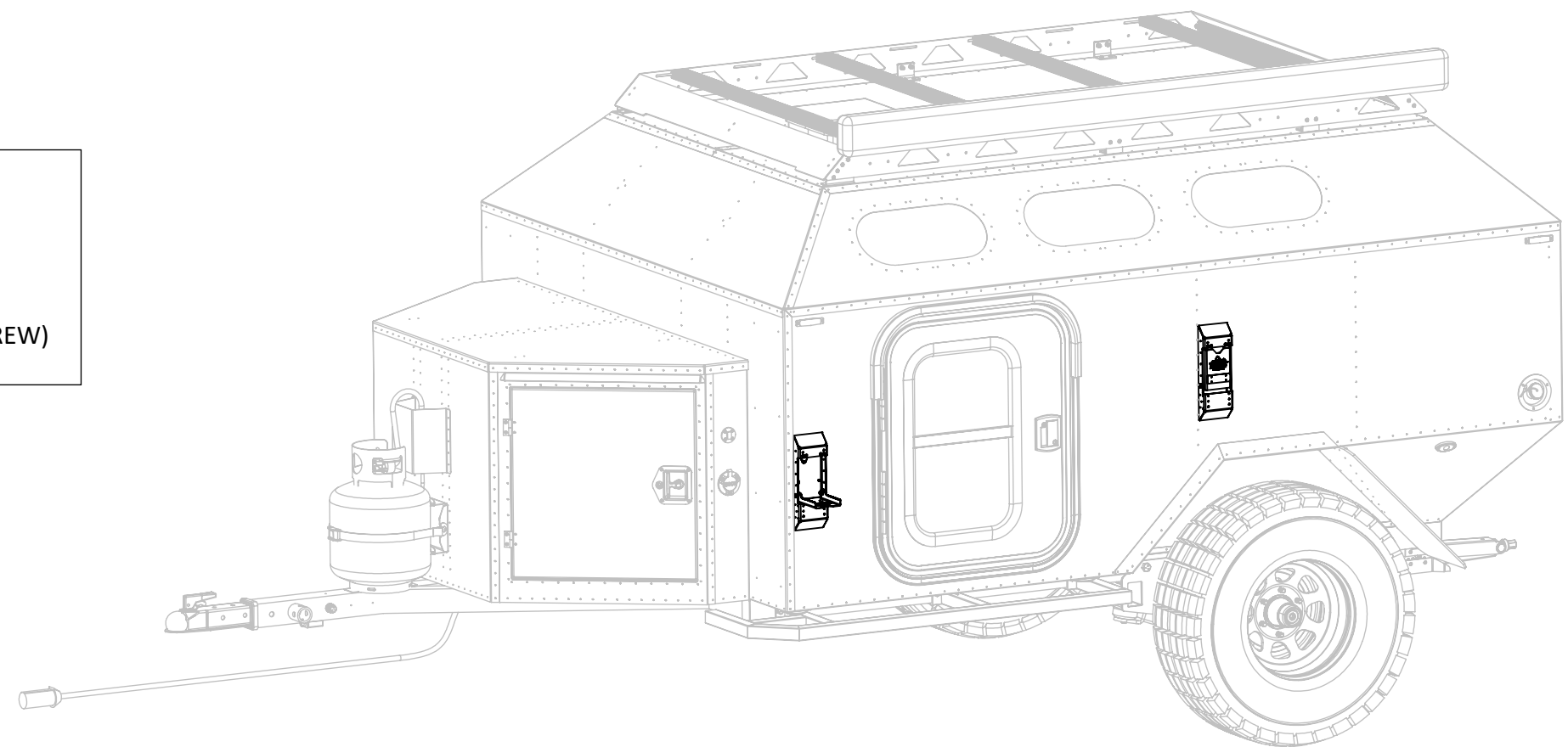

**Step 1:**

*NOTE: BE CAREFUL OF WIRES IN THE WALLS WHEN DRILLING*  
-DRILL #30 holes and UPSIZE them to 25/64" using provided drill template

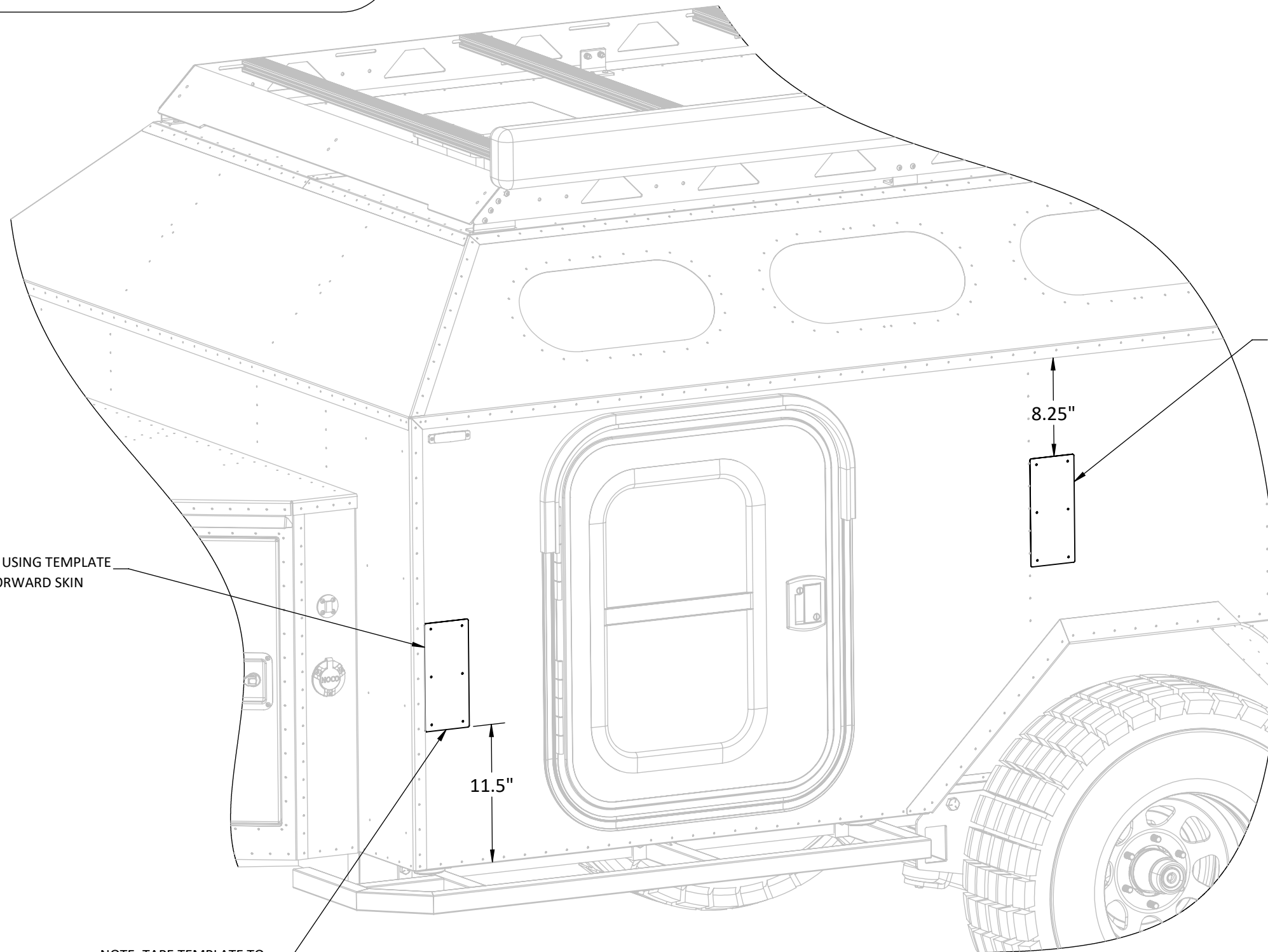

6X MARK AND DRILL TO 25/64" USING TEMPLATE  
ALIGN WITH RIVET HEADS ON THE LEFT SIDE OF THE TEMPLATE

6X MARK AND DRILL TO 25/64" USING TEMPLATE  
MOUNTED UP AGAINST FORWARD SKIN

NOTE: TAPE TEMPLATE TO  
THE WALL IF NECESSARY

**Step 2:**

-REPEAT for other side

**Step 1:**

-INSTALL rivnuts as shown

6X RN-0.250-20

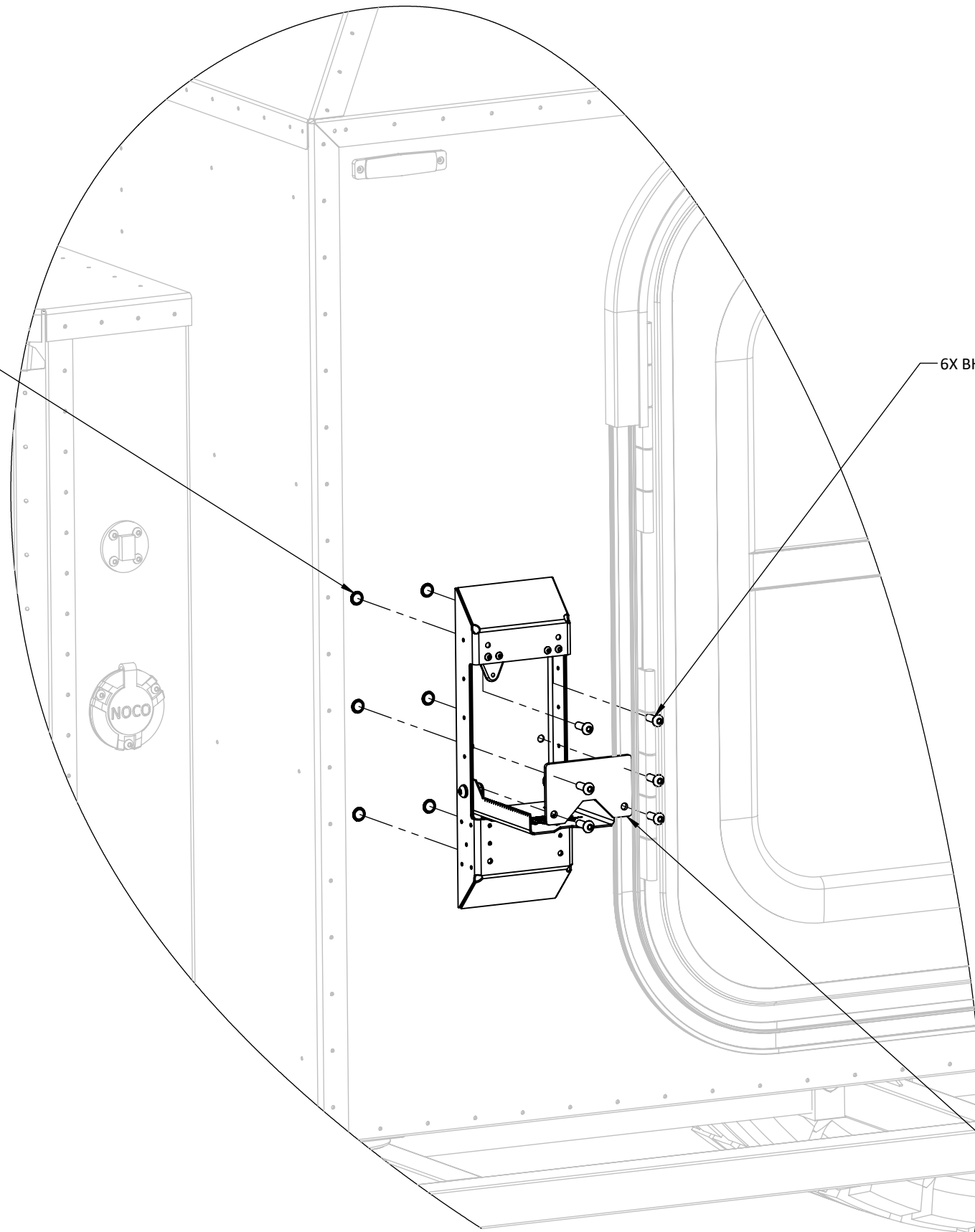

6X BHS-0.250-20-0.750

**Step 2:**

-ATTACH step assembly with the bottom screws holding the step spacer

520217

**Step 1:**  
-TIGHTEN screws

NOTE: HOLES TO PASS HEX WRENCH THROUGH

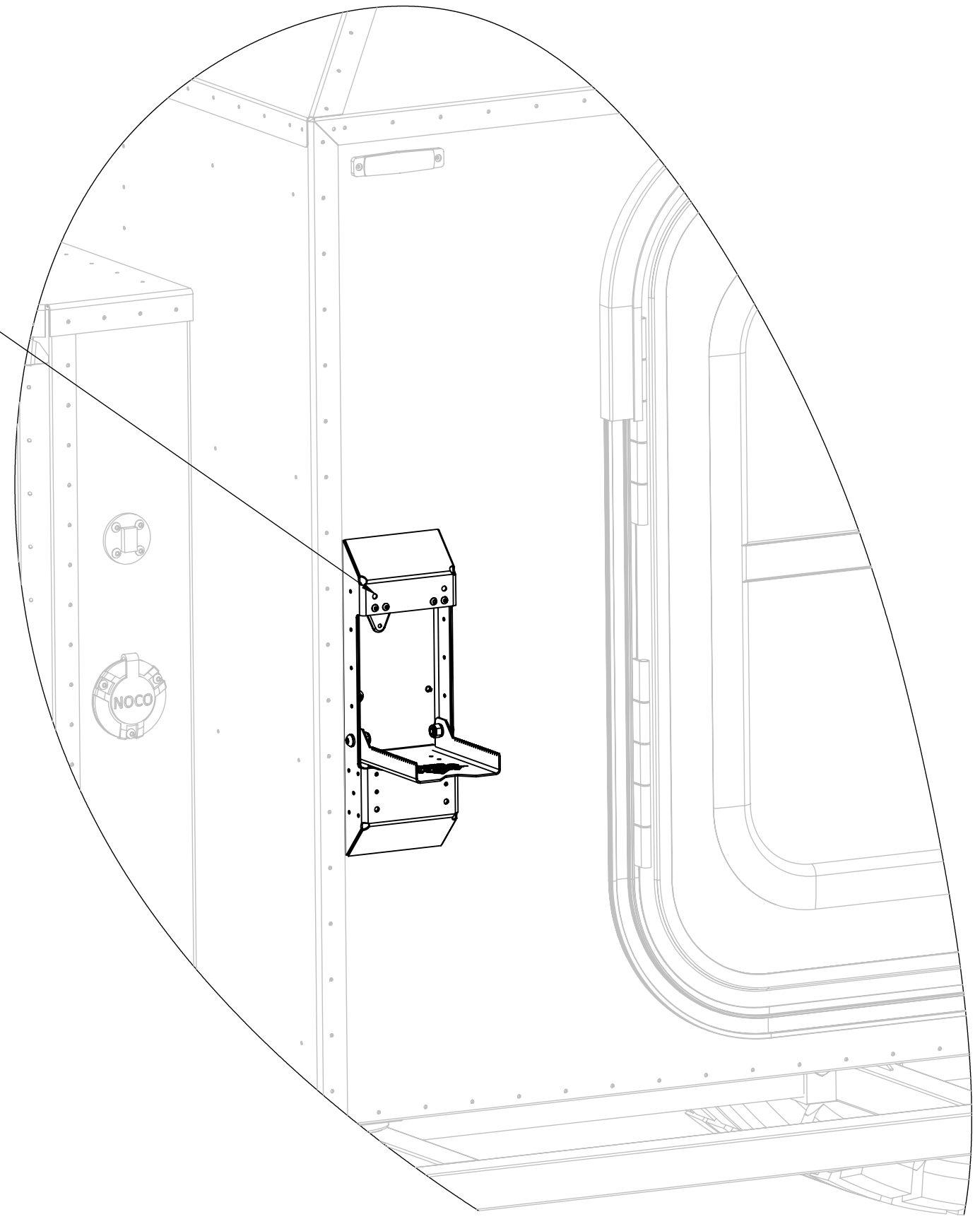

**Step 2:**  
-REPEAT installation for all other steps